

This document is the property of Hatteland Technology AS.  
 This document and any authorized reproduction thereof, must not be used in  
 any way against the interest of Hatteland Technology AS.  
 Any authorized reproduction, in whole or in part, must include this legend.

HATTELAND DISPLAY STANDARD		Created by:	Date:	Modified by:	Date:	Revision:
Material type and Quality:		Surface treatment:				
Aluminium 5052, standard EN 485-2 (1 & 2)		(1) TRIKATON (Zinc/Mangan Phosphatizing)				
Ss-37 Alu./Znk, standard EN 10215 (1)		(2) Powder coating RAL 9011 EPOXY STRUCTUR				
Stainless Steel A316 L, standard EN 464		Du. Flott: EP301-490327				
Welding specification		Tolerance:				
NS-EN-288-4		ISO 2768-1 middel				
Sheet metal fasteners:						
PSM International or equivalent (www.psminternational.com)						

# FRONT VIEW

# SIDE VIEW

# BACK VIEW

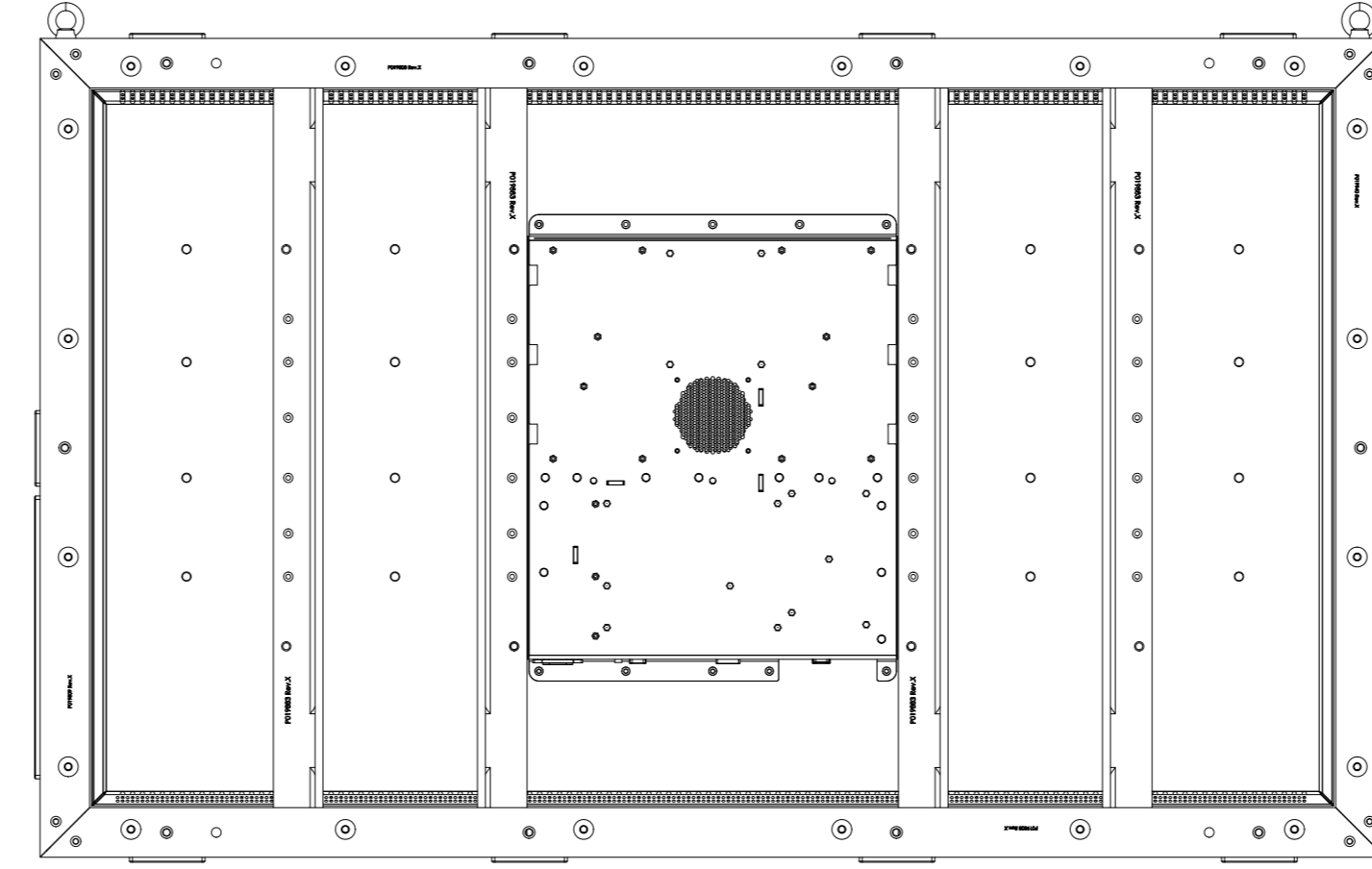
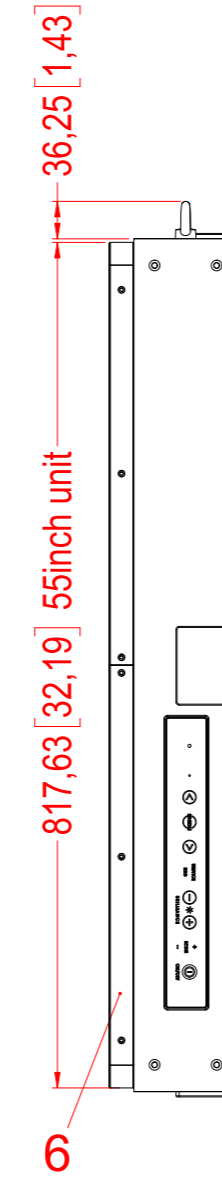
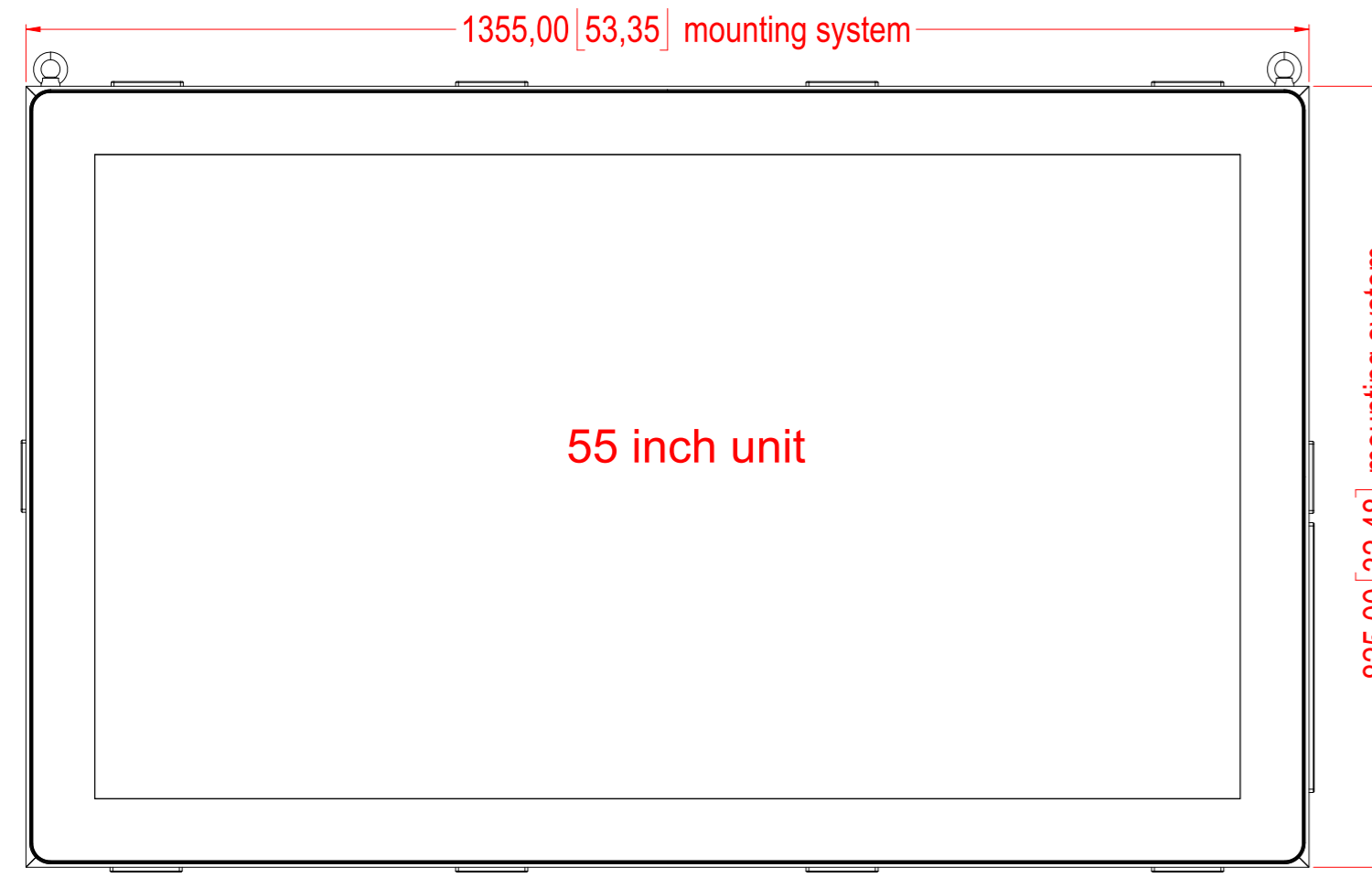

10 x thread M8  
 10x prevailing torque nut M8  
 provide by customer

40,00 [1,575] max. and min. thread length  
 25,00 [0,984]

# TOP VIEW

# DIMETRIC VIEWS

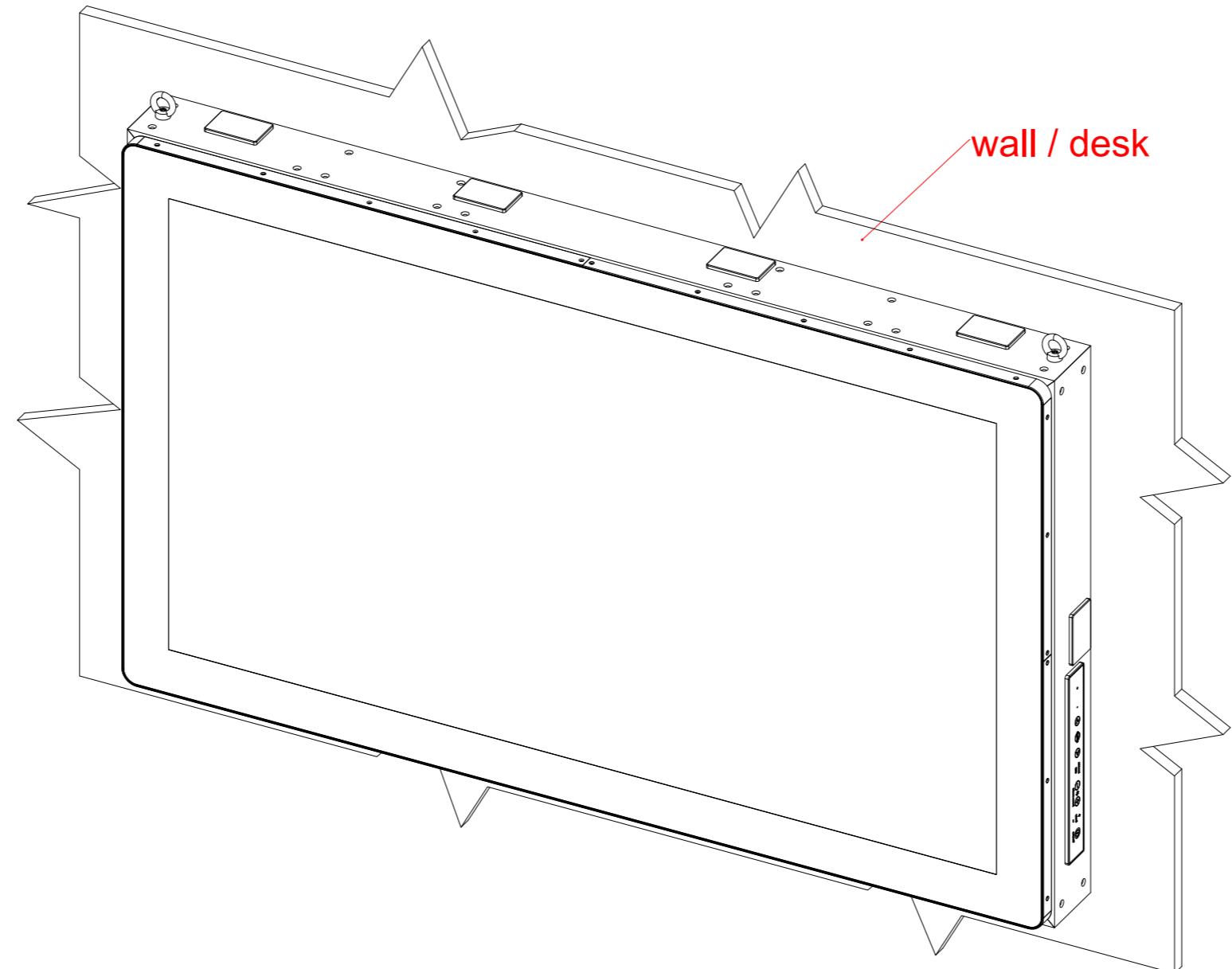
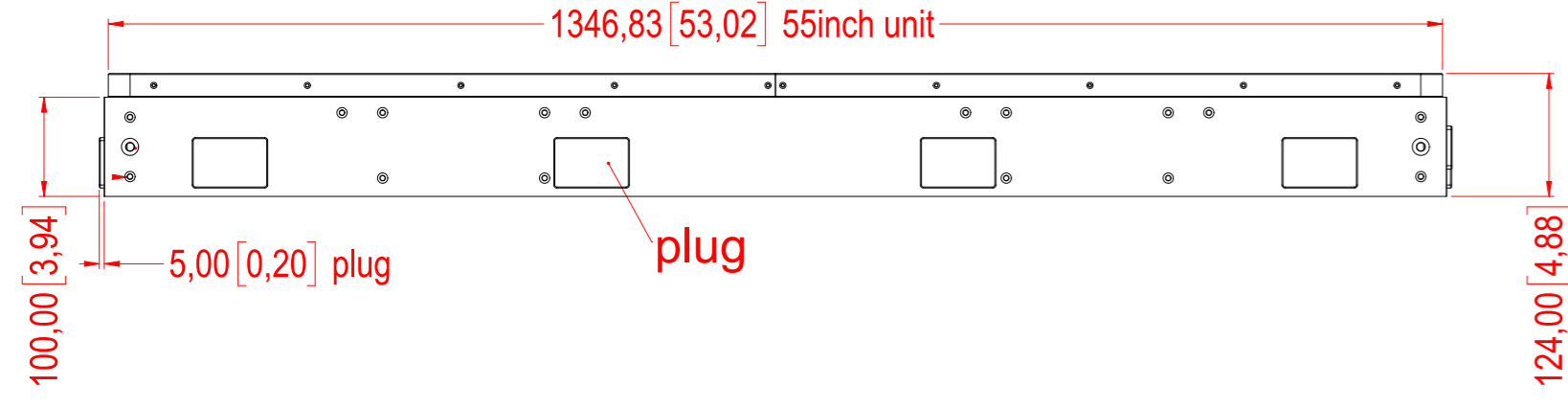

# WALL MOUNT POINTS

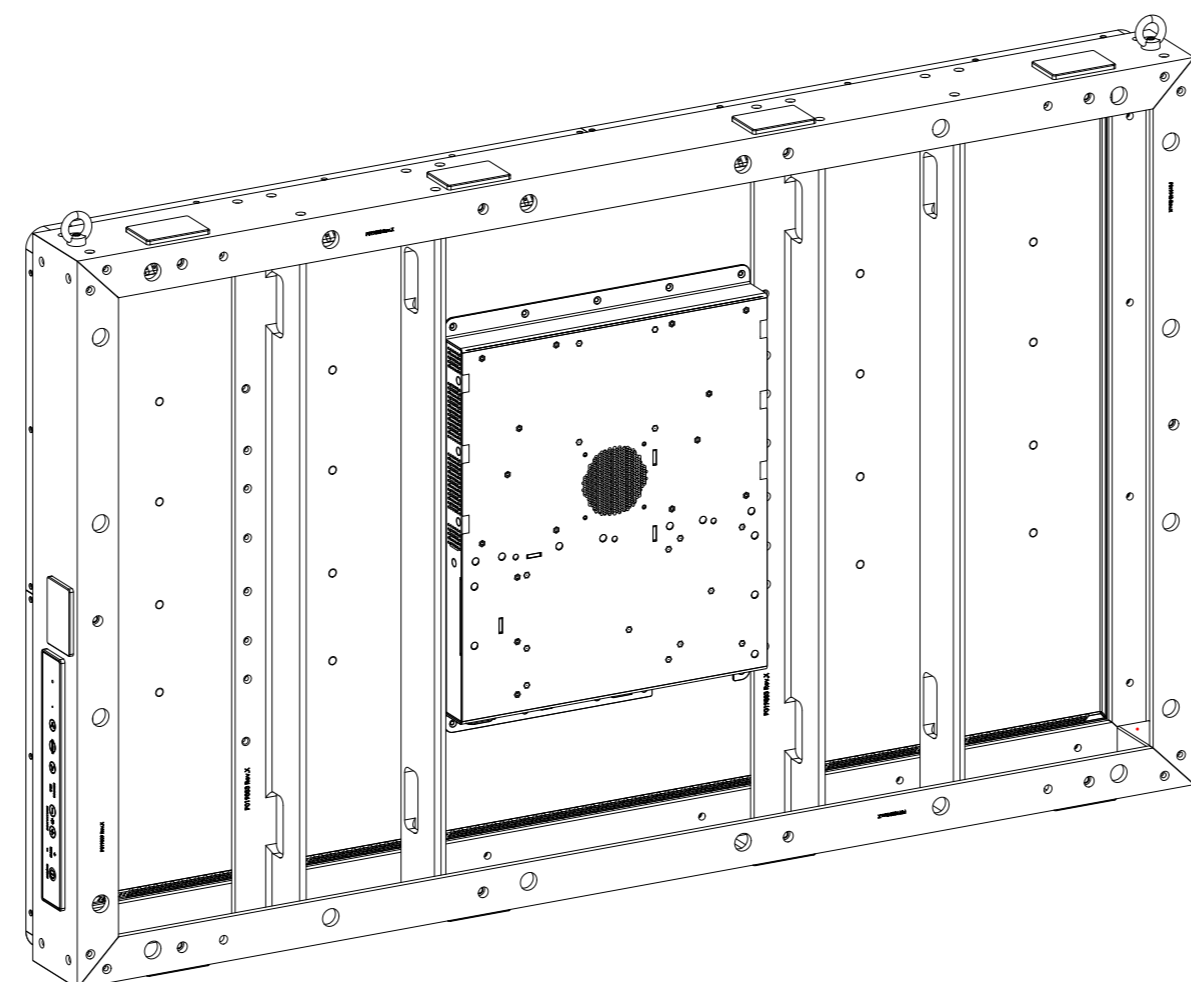
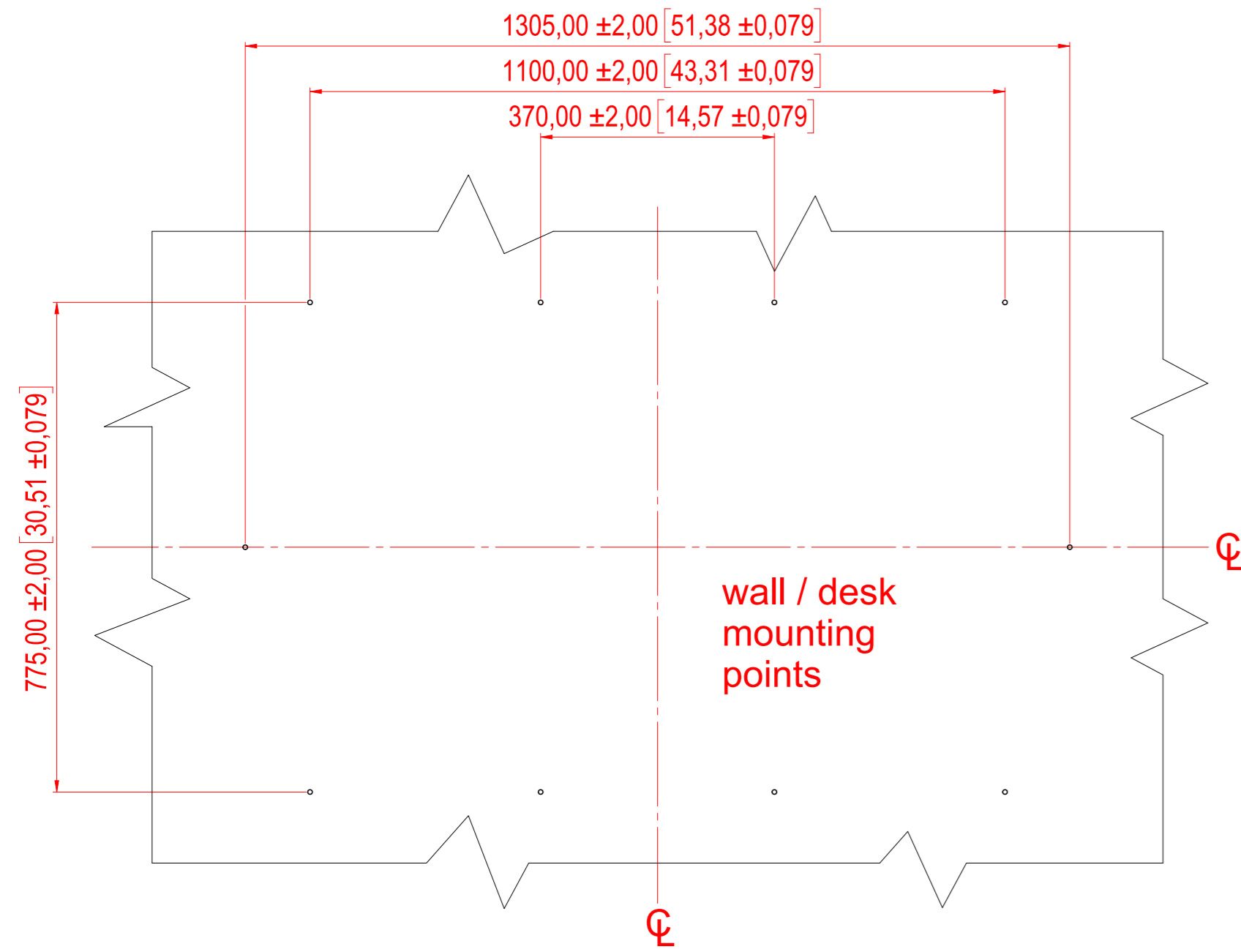

# CONNECTOR VIEW

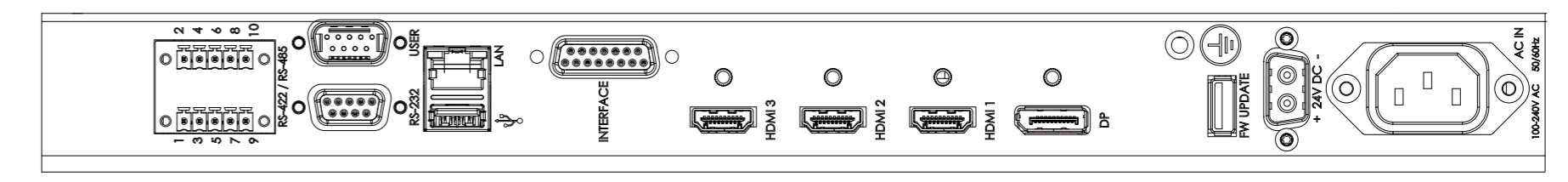

**SALES DRAWING HD 55T22 MVD-MA1-AOGA (Wall Mount)**  
 shown in this drawing, but measurements generally apply for all HD 55T22 MVD-MAx-AOGx models.

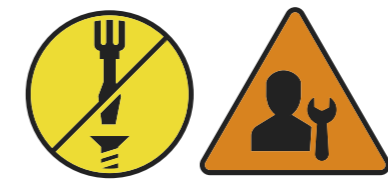

Date:	Mechanical Designer:	Projection:	Size: A1 Format	<b>HATTELAND TECHNOLOGY</b> an EMBRON Company
			Scale:	
Hatteland Technology AS Eikeskogvegen 52 N-5570 Aksdal		Approved by:	Colour code:	Revision:
		Drawing number:	Surface treatment:	A009832

Units: mm [inches]